

OMGT6743 Homework #2 – Materials Requirements Planning

Product Tree Structure

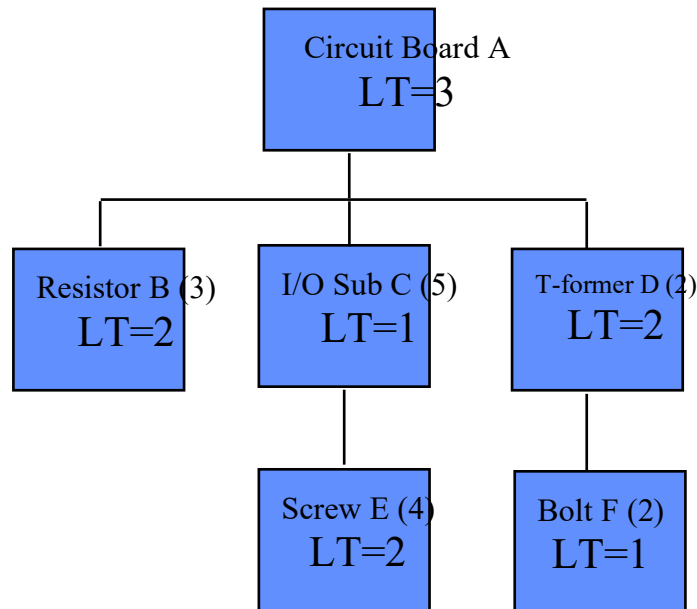

<u>Item</u>	<u>On Hand</u>	<u>Scheduled Receipts</u>	<u>Lot Size</u>	<u>MPS</u>
Circuit Board A	11	0	1	100 period 6, 320 period 7, 270, period 8
Resistor B	51	0	10	---
I/O Sub C	14	0	17	---
T-former D	20	0	40	---
Screw E	125	0	25	---
Bolt F	100	0	100	---

Judy needs to know how much of each component to order and when to order them. Help her set up an MRP schedule. This deliverable should include a short narrative describing how the MRP was set up and what the outcome is (speak specifically to items that are past due and all item order dates and amounts).

